

COBRA CLASS

7

TABLE OF CONTENTS

	PAGE
INSTRUCTIONS	2
SPECIFICATIONS	2
MACHINE INSTALLATION	2
MOTOR INSTALLATION	3
FOOT PEDAL AND COUPLING LEVER INSTALLATION	3
PRESSER FOOT PEDAL INSTALLATION	4
BOBBIN WINDER INSTALLATION	4
THREAD STAND INSTALLATION	5
PREPARATION BEFORE USE	5
LUBRICATION	5
COMMISSIONING	6
SET THE NEEDLE	6
REMOVE THE BOBBIN	7
THREAD THE NEEDLE	8
ADJUST STITCH LENGTH	8
ADJUST PRESSER FOOT LIFT	9
ADJUST NEEDLE THREAD	9
ADJUST PRESSURE OF PRESSER FOOT	10
PARTS LIST & ILLUSTRATIONS	11

1. INSTRUCTIONS

GA733 is a top and bottom feed extra heavy duty sewing machine which has a special designed high rigidity machine frame. It's very easy for sewing large products on the big working space. GA733 have super force and sewing capacity from large inertia pulley. Alternating presser feet and feed dog feeding mechanism make good stitching performance and material feed. It's a well-suited machine of sewing extra heavy duty material and multilayer material. GA733 also have good performance on sewing of slipped and sticky material. Cam type take-up and half rotary extra large shuttle hook are installed to form the seam. The large hook can increase volume of winding, improve work efficiency. GA733 is a ideal machine for sewing auto products (air-bag, seat cushions, life belt, etc.), handbags, baseball gloves, harness, tents, polishing wheel, parachute bag, suitcase, golf bag, sail and bookbinding.

2. SPECIFICATIONS

Model	GA733	
Max. sewing speed	700s.p.m	
Stitch length	10-15mm	
Presser foot lift	By hand	29mm
	By knee	32mm
Needle size	SM×1000 27#	
Thread	0#-00#	
Shuttle hook	KSP7-31	
Lubrication	Manual	
Motor	550W Clutch motor 1400r.p.m	

3. MACHINE INSTALLATION

3.1 Place

The GA733 heavy duty sewing machine should be mounted in a stabilization base. Place shockproof rubber washer between machine stand and ground will reduce the shock of machine and operating noise.

3.2 Bed bracket and oil pan installation

Mounting the bed bracket under sewing table and then fix the oil pan on the bracket by screw.

3.3 Machine installation

Place the machine on the bed bracket by four supporting foot and adjust the machine into steady position.

4. MOTOR INSTALLATION

Mounting the motor by three motor mounting screw. Adjust the position of motor(C) and make the balance wheel(Machine pulley) belt guidance and motor pulley belt guidance are collinear. Observe the Fig. 1.

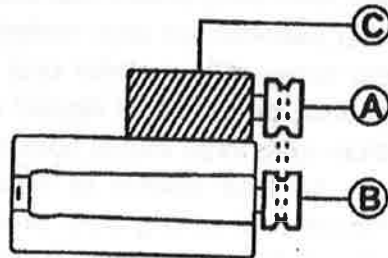

Fig.1

5. FOOT PEDAL AND COUPLING LEVER INSTALLATION

- 5.1 Foot pedal(A) should be mounted as 20° - 30° angle between ground.
- 5.2 Adjust the coupling lever(E) and make collinear of machine pull rod(B) and coupling lever(C).
- 5.3 The machine rotation direction should be anticlockwise look from machine pulley(G) side. The motor(D) should be running in same direction.
- 5.4 Regulate timing belt tension by changing height of motor. Pressing the lateral of timing belt, if the timing belt can be extrude 10-12mm and restate after release, the timing belt will in a suitable tension.
- 5.5 The mounted position of foot pedal can be adjusted according to work habit of operator. Observe the Fig.2.

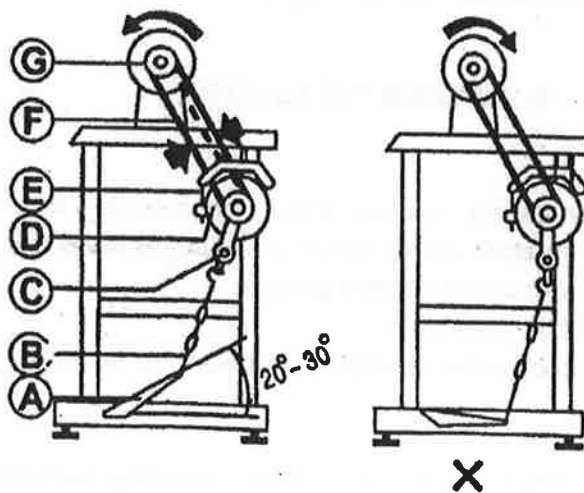

Fig.2

6. PRESSER FOOT PEDAL INSTALLATION

Link the presser foot left chain(A) and presser foot left rod(C) by hook(A). Mounted presser foot pedal(D) on machine stand crosspiece. Adjust board(E) position and fixed all bolt and nut. Observe the Fig.3.

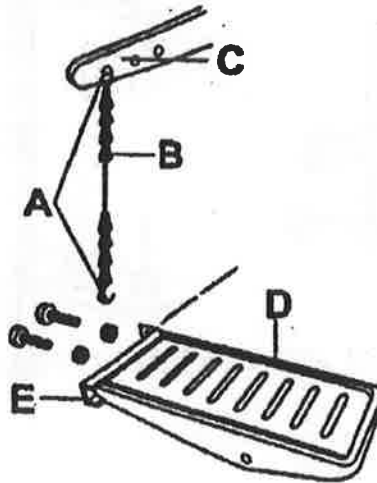

Fig.3

7. BOBBIN WINDER INSTALLATION

The bobbin winder is mounted on the table top as shown in Fig.4 with its pulley in front of the driving belt so that the pulley will separate from the belt after bobbin has been wound with sufficient thread.

Screw(B) adjust the central position of bobbin winder.

Screw(C) adjust the bobbin winder.

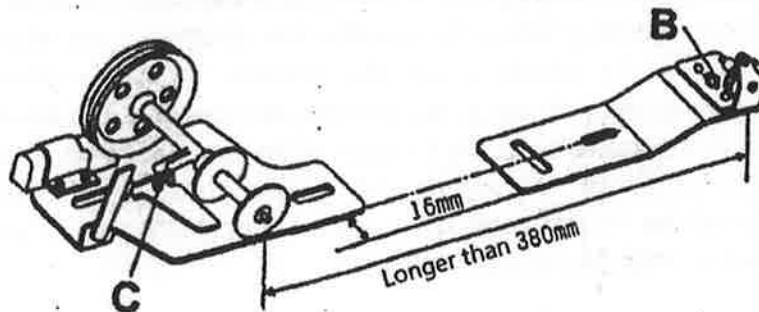

Fig.4

8. THREAD STAND INSTALLATION

The thread stand should be mounted in top right corner of table top, fixed by nut(C).

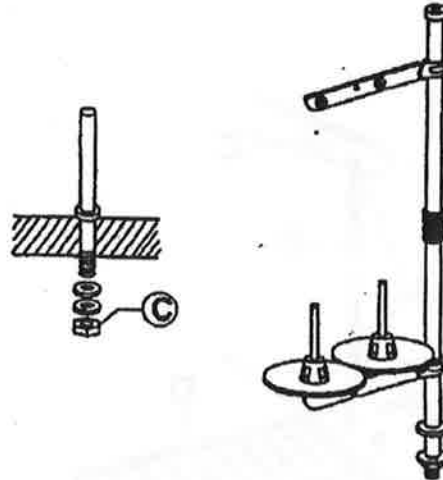

Fig.5

9. PREPARATION BEFORE USE

9.1 Before packing, we put anti rust grease in the component of machine. Please wipe off the grease in the surface and clean the machine.

9.2 Check

Please check the machine carefully and turn rotatable parts.

10. LUBRICATION

To insure easy running and prevent unnecessary wear of the machine, oil all parts which are in movable contact. When the machine is in continuous use, oil should be applied frequently. The places where the machine should be oiled are indicated in Fig.6 by arrows pointing to the oil holes and bearings. Oil should be regularly applied to the shuttle race. On the back of the arm is a cover, fastened by two knurled screws loosen the screws and remove cover. Care should be taken to see that all the moving parts inside are sufficiently lubricated. Replace cover into position and tighten the two screws.

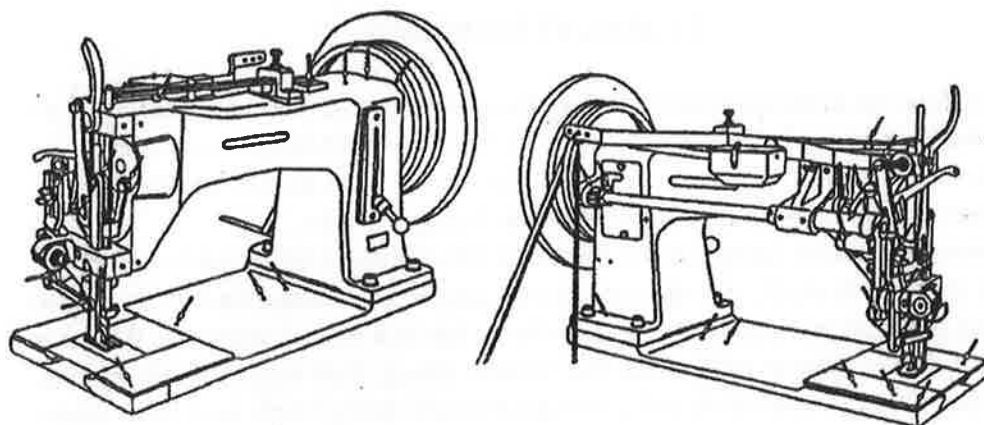

Fig.6

11. COMMISSIONING

The new machine should be commissioning operation in low speed. Lift the presser foot and control the operation speed in 300-400 stitch per minute for half hour.

12. SET THE NEEDLE

Rotate the balance wheel until the needle bar has reached its highest position. Loosen the thumb nut in the needle clamp and place the needle up into the clamp as far as it will go. The long groove of the needle must be facing left and the eye in line with the arm of the machine. Then tighten the set screw. Observe the Fig.7.

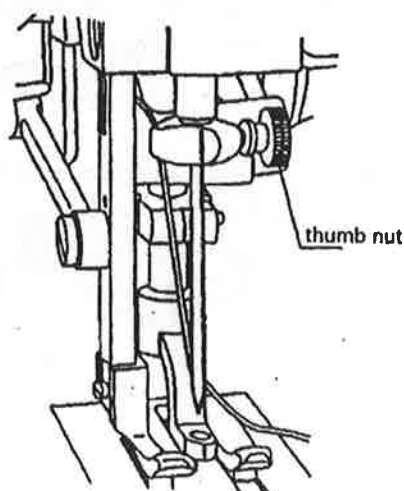

Fig.7

13. REMOVE THE BOBBIN

13.1 Rotate the balance wheel bringing the needle bar to its lowest position. Then with the curved part of the shuttle cylinder opener, which should conform to the curve of the shuttle, as shown in Fig.8 a, insert the small end of shuttle cylinder opener into slot in the spring latch under the shuttle cylinder.

13.2 Hold the bobbin between the thumb and index finger of the left hand, at the same time the thread is drawing off from the underside toward the right as shown in Fig.8 b. Place the bobbin in the cylinder as far as it will go, draw the thread in the slot in the cylinder and under the tension spring, then into the delivery eye, then push the cylinder back until it is locked by the spring latch, and allow about 3 inches of thread to hang free from the shuttle so that it can be drawn up through the throat plate.

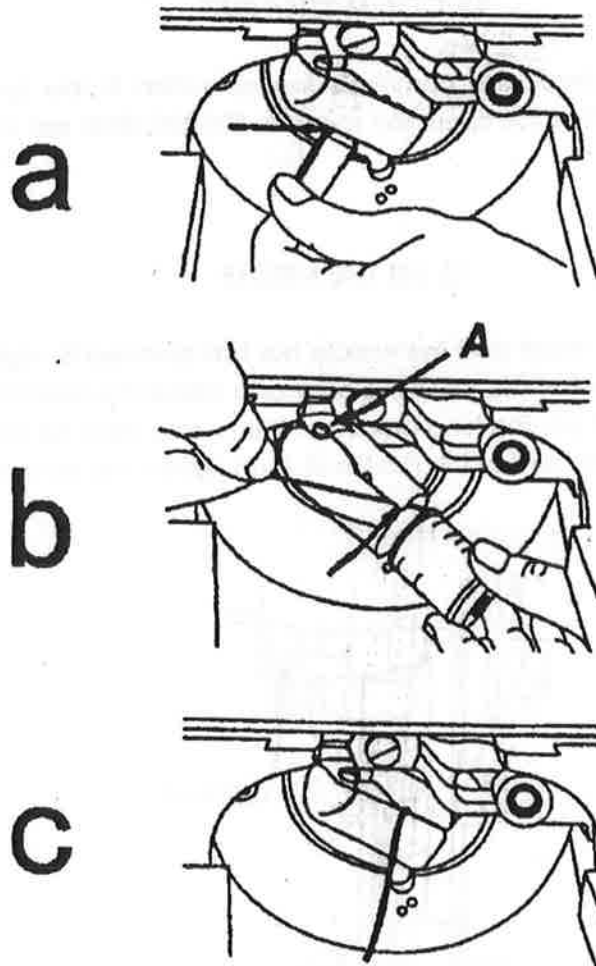

Fig.8

14. THREAD THE NEEDLE

Observe the Fig.9.

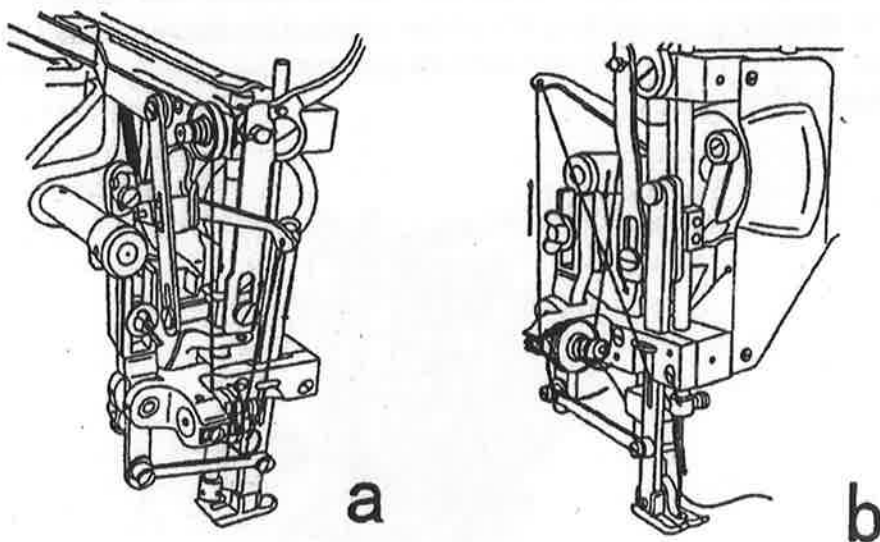

Fig.9

15. ADJUST STITCH LENGTH

The length of stitch is regulated by loosening the serrated nut(A) on the reverse lever, Fig.10.

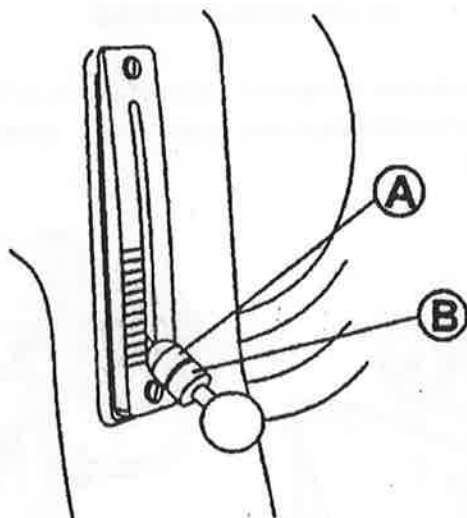

Fig.10

16. ADJUST PRESSER FOOT LIFT

16.1 The presser foot lift can be adjusted by Screw(C). If the screw(C) goes up, the lift of presser foot and alternating presser foot will reduce, vice versa.

16.2 The alternating presser foot lift can be adjusted by slides(D). If the slides(D) goes up, the lift of presser foot and alternating presser foot will reduce, vice versa.

16.3 Observe the Fig.11.

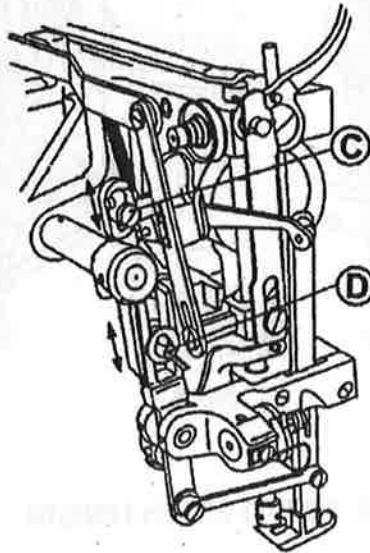

Fig.11

17. ADJUST NEEDLE THREAD

Turning the tension nut clockwise, increase tension of the needle thread.

Turning the tension nut counterclockwise, reduce the tension of the needle thread. Observe the Fig.12.

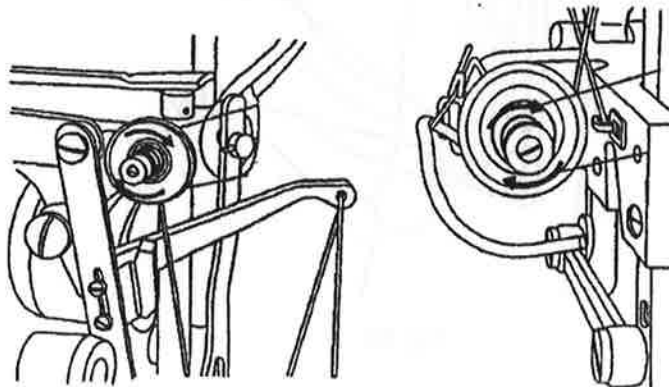

Fig.12

18. ADJUST PRESSURE OF PRESSER FOOT

The pressure of presser foot should be adjusted basing on sewing material. Observe the Fig.13, turn the nut clockwise or counterclockwise to adjust the pressure of presser foot.

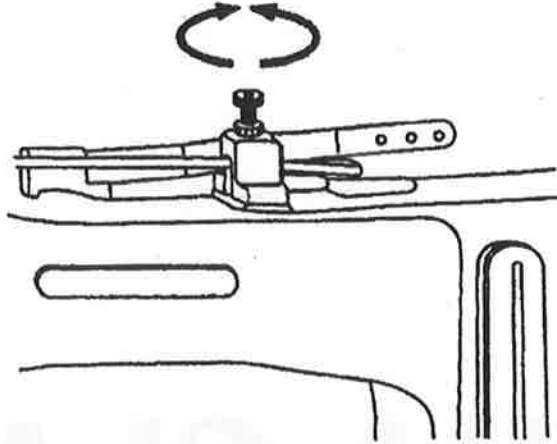

Fig.13

FOR THE RECORDS OF THE BOARD OF DIRECTORS

Minutes of the meeting of the Board of Directors of the University of California, held on the 15th day of May, 1968, at 10:00 a.m. in the Board Room, University of California Administration Building, Berkeley, California.

COBRA CLASS

7

Parts List !!

1. CASTING COMPONENTS

No.	Parts No.	Name	Qty	Remark
1	7KT2-004	Cover	1	
2	7KT2-005	Screw	3	
3	7KT2-005	Screw	1	
4		Oil cup	2	
5		Oil cup	1	
6	7KT2-006	Cover	1	
7	7KT2-007	Screw	2	
8	7KT2-008	Take-up Lever Shield	1	
9	13WF2-018	Screw	2	
10	7KT2-009	Face Plate	1	
11	7KT2-010	Screw	2	
12	7KT2-011	Slide Plate(L)	1	
13	7KT2-012	Slide Plate(R)	1	
14	1WF2-044	Screw	2	
15	7KT2-013	Needle Plate	1	
16	7KT2-014	Screw	2	
17	7KT2-015	Tension Stud	1	
18	7KT2-016	Tension Disc	2	
19	6K4-021	Tension Spring	1	
20	7KT2-018	Nut	1	
21		Oil Cup	3	
22	7KT2-033	Machine Supporting Bolt	4	
23		Washer	4	GB7244-87-14
24	7KT2-034	Pin	2	
25	7KT2-035A	Name Plate	1	
26	16WF2-053	Trademark Plate	1	
27		Rivet	4	
28	1KT1-005	Caution Plate	1	
29	7KT2-036	Triangle Caution Plate	1	
30	7KT2-001	Housing	1	
31	7KT2-002	Housing Plate	1	
32	7KT1-004	Thread Take-up Lever Mounted Plate	1	
33	7KT1-003	Screw	3	
34	7KT2-003	Spring	1	
35	4KT1-005	Serial No. Plate	1	
36	35WF1-054	Rivet	2	

1. CASTING COMPONENTS

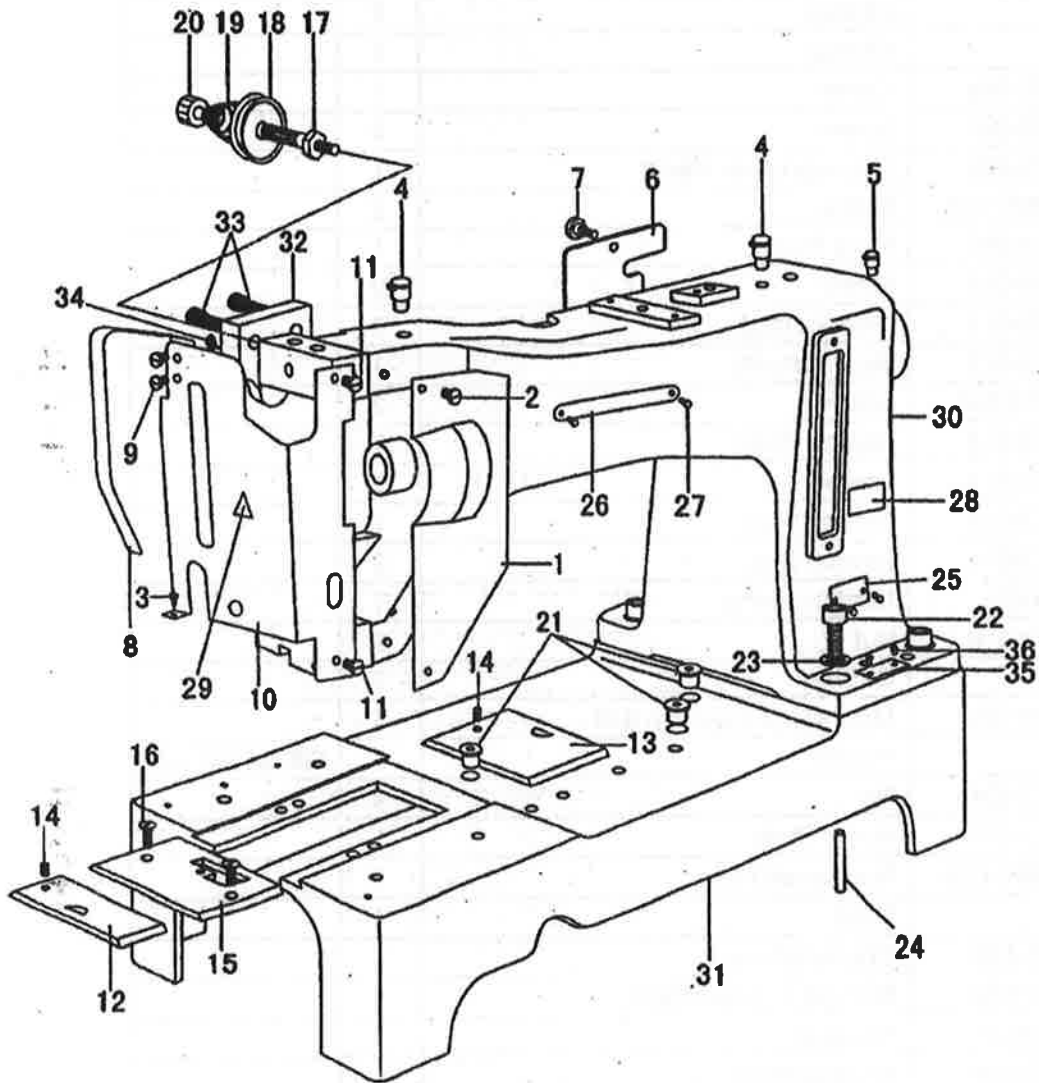

2. UPPER SHAFT AND THREAD TAKE-UP COMPONENTS

No.	Parts No.	Name	Qty	Remark
1	7KT1-008	Upper Shaft	1	
2	7KT1-009	Thread Take-up Cam	1	
3	7KT1-010	Screw	2	
4	7KT1-052	Tapered Pin	1	
5	7KT1-011	Upper Shaft Bushing(R)	1	
6	7KT1-012	Setscrew	1	
7	7KT6-001	Balance Wheel	1	
8	7KT1-014	Screw	2	
9	7KT1-002	Thread Take-up Lever	1	
10	7KT1-001	Hinge Screw	1	
11	7KT1-005	Fulcrum Pin	1	
12	7KT1-006	Screw	1	
13		Washer	1	G8859-87-8
14	7KT1-007	Nut	1	
15	7KT1-015	Hinge Screw	1	
16	7KT1-016	Nut	1	
17	7KT1-017	Link	1	
18	7KT1-018	Bushing	2	
19	7KT1-019	Setscrew	2	
20	7KT1-020	Needlebar Connect Stud	1	
21	7KT1-010	Setscrew	2	
22	7KT1-021	Needlebar	1	
23	7KT1-022	Needle Clamp	1	
24	7KT1-023	Needle Clamp Screw	1	
25		Needle	1	1000H 27#
26	7KT1-025	Connecting Rod	1	
27	7KT1-024	Cap Screw	2	
28	6K1-042	Balance Wheel Screw	1	

2. UPPER SHAFT AND THREAD TAKE-UP COMPONENTS

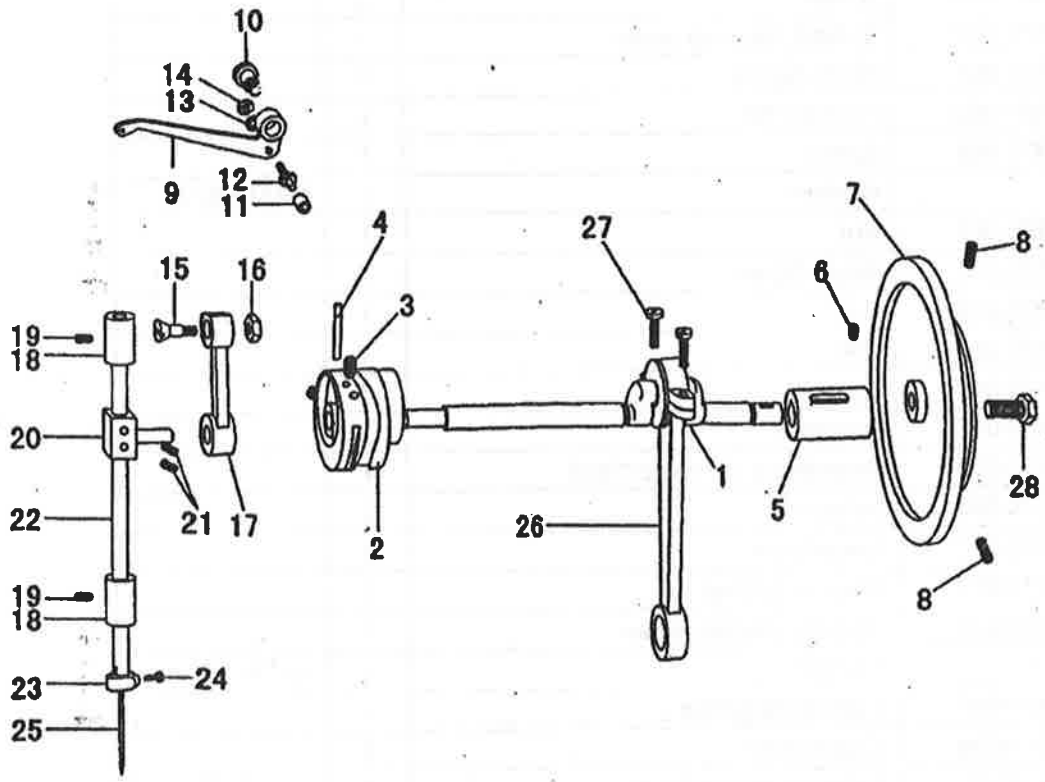

3. OSC. SHAFT AND SHUTTLE HOOK COMPONENTS

No.	Parts No.	Name	Qty	Remark
1	7KT1-031	OSC. Shaft	1	
2	7KT1-028	Shuttle Driver	1	
3	7KT1-010	Setscrew	1	
4	7KT1-053	Pin	1	
5	7KT1-029	Shuttle Race Frame	1	
6	7KT1-030	Screw	1	
7	7KT1-046	Bobbin	1	
8	7KT1-048	Shuttle Race	1	
9	7KT1-047	Setscrew	2	
10	7KT1-049	Race	1	
11	7KT1-050	Spring	1	
12	7KT1-051	Screw	1	
13		Shuttle	1	KSP7-31
14	7KT1-043	Collar 1	1	
15	7KT1-044	Collar 2	1	
16	7KT1-045	Setscrew	4	
17	7KT1-036	OSC. Shuttle Crank	1	
18	7KT1-053	Pin	1	
19	7KT1-010	Setscrew	2	
20	7KT1-038	Slide Shuttle	1	
21	7KT1-039	Spacer	1	
22	7KT1-040	Nut	1	
23	7KT1-041	Slide Plate	1	
24	7KT1-042	Screw	1	
25	7KT1-037	OSC. Rock Shuttle	1	
26	7KT1-032	Oil Tube Packing	1	
27	7KT1-033	Nut	2	
28	7KT1-034	Stud	1	
29	7KT1-035	Hinge Pin	1	
30	7KT1-026	Hinge Screw	1	
31	7KT1-027	Nut	1	

3. OSC. SHAFT AND SHUTTLE HOOK COMPONENTS

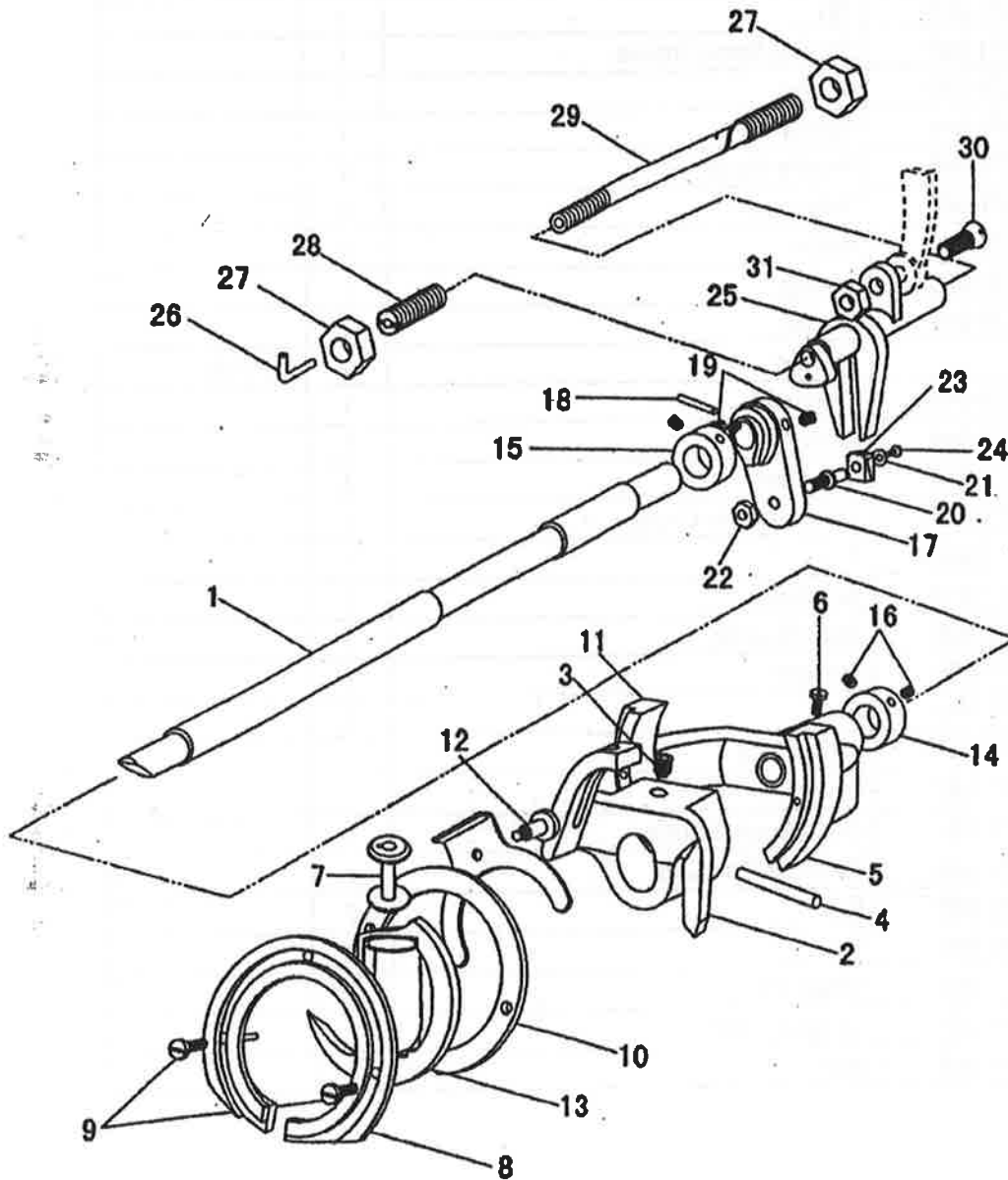

4. PRESSER COMPONENTS

No.	Parts No.	Name	Qty	Remark
1	7KT3-021	Slide Block	1	
2	7KT3-022	Sleeve	1	
3	7KT3-023	Sleeve	1	
4	7KT3-028	Presser Bar	1	
5	7KT1-018	Bushing	1	
6	7KT5-002	Setscrew	1	
7	22T2-005B3	Setscrew	1	
8	7KT3-029	Presser Foot	1	
9	7KT3-013	Spring	1	
10	7KT3-014	Pin	1	
11	7KT3-012	Bracket	1	
12	7KT3-011	Screw	2	
13	7KT3-009	Bolt	1	
14	7KT3-010	Nut	1	
15	7KT3-024	Shield Mounted Base	1	
16	7KT3-025	Shield	1	
17	7KT3-026	Setscrew	1	
18	7KT3-027	Setscrew	1	
19	7KT3-004	Lifter	1	
20	7KT3-003	Washer	1	
21	7KT3-002	Stud	1	
22	7KT3-001	Washer	1	
23		Spacer	1	GB879-86 3×2
24	7KT3-006	Bracket	1	
25	7KT3-005	Screw	2	
26	7KT3-007	Nut	1	
27	7KT3-008	Stud	1	
28	7KT3-017	Hinge Screw	1	
29	7KT3-018	Bar	1	
30	37T4-416	Screw	2	
31		Nut	2	GB97.1-85-4
32	7KT3-019	Bracket	1	
33	7KT3-020	Hinge Screw	1	
34	7KT3-015	Bar	1	
35	7KT3-016	Screw	1	
36	7KT3-041	Flat Spring	1	
37	7KT3-039	Screw	1	
38	7KT3-038	Nut	1	
39	7KT3-037	Spring	1	
40	7KT3-036	Screw	1	

4. PRESSER COMPONENTS

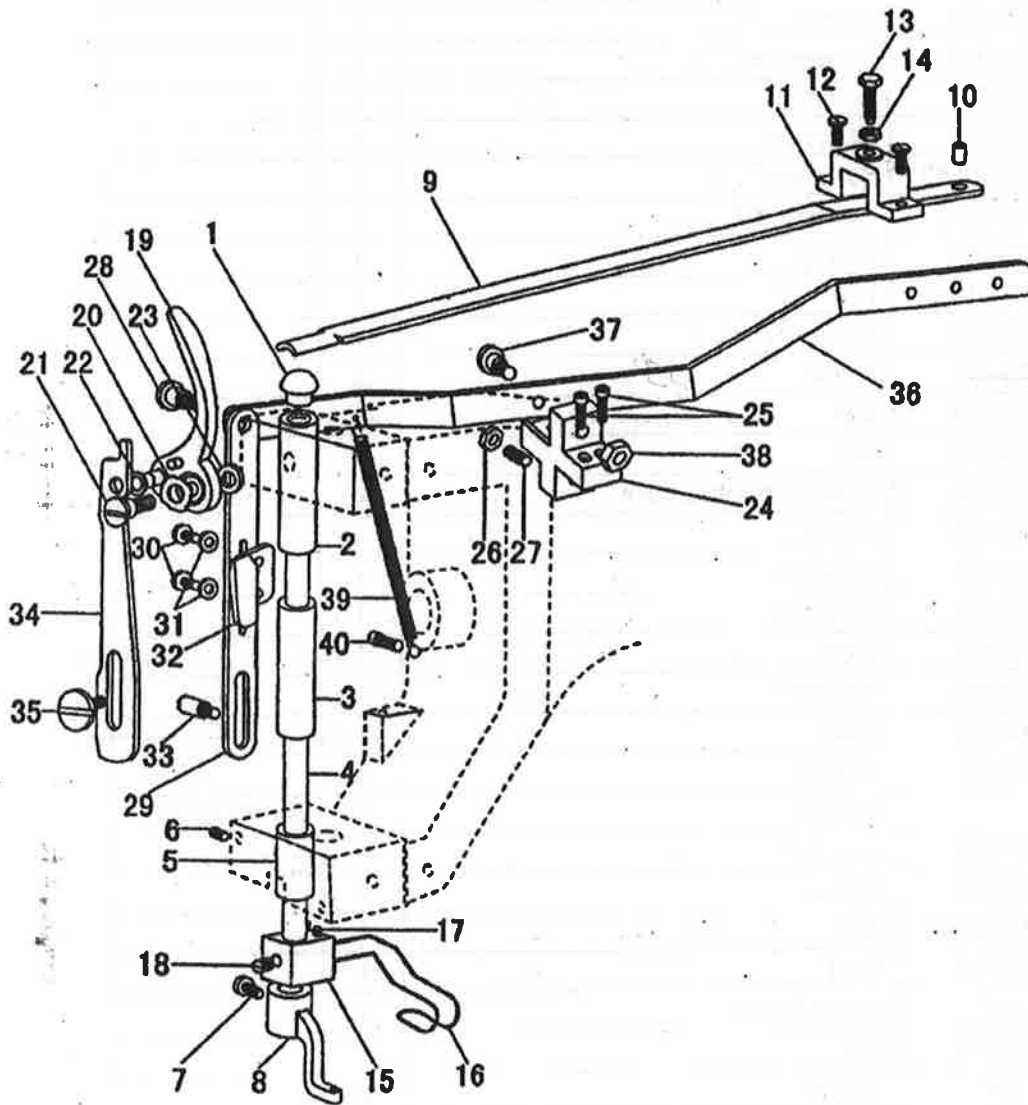

5. LOWER FEEDING COMPONENTS

No.	Parts No.	Name	Qty	Remark
1	7KT4-001	Feed Bar	1	
2	7KT4-002	Screw	1	
3	7KT4-003	Feed Dog	1	
4	7KT4-004	Screw	2	
5	7KT1-016	Nut	2	
6	7KT4-005	Feed Rock Shuttle	1	
7	7KT4-006	Screw	2	
8	7KT4-007	Screw	2	
9	7KT1-033	Nut	4	
10	7KT4-012	Rock Shuttle	1	
11	7KT4-015	Plate	1	
12	7KT1-030	Screw	1	
13	7KT5-055	Pin	1	
14	7KT4-008	Crank	1	
15	7KT4-009	Screw	1	
16	7KT4-010	Fulcrum Pin	1	
17	7KT4-011	Roller	1	
18	7KT4-016	Stitch Regulate Cam	1	
19	7KT1-010	Setscrew	2	
20	7KT4-025	Stitch Regulate Frok	1	
21	7KT4-026	Screw	3	
22	7KT1-016	Nut	3	
23	7KT4-013	Screw	1	
24	7KT4-014	Crank	1	
25	7KT4-020	Arm	1	
26	7KT4-023	Fulcrum Pin	1	
27	7KT4-024	Screw	1	
28	7KT4-019	Screw	1	
29	7KT4-017	Stitch Regulate Link	1	
30	7KT4-022	Screw	1	
31	7KT4-021	Nut	1	
32	7KT4-027	Spring	1	
33	7KT4-028	Stitch Regulate Stud	1	
34	7KT4-018	Screw	1	
35	7KT4-029	Stitch Plate	1	
36	7KT4-030	Screw	2	
37	7KT4-031	Nut	1	
38	7KT4-032	Washer	1	
39	7KT4-033	Nut	1	
40	7KT4-034	Ball Handle	1	

41	7KT4-035	Screw	2	
42	7KT4-036	Plate	1	

5. LOWER FEEDING COMPONETS

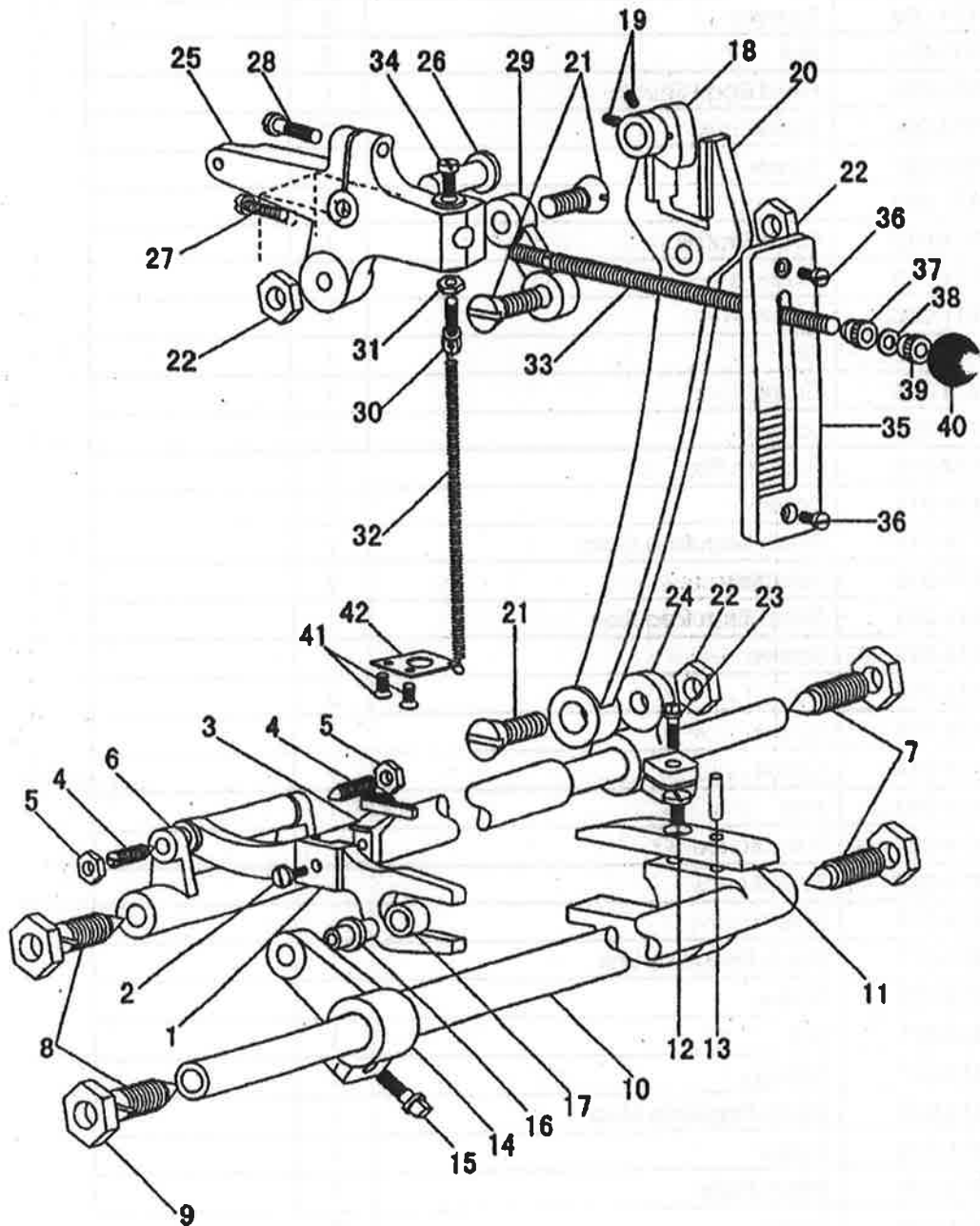

6. UPPER FEEDING AND THREAD TENSION COMPONENTS

No.	Parts No.	Name	Qty	Remark
1	7KT5-001	Sleeve	1	
2	7KT5-057	Shaft	1	
3	7KT5-004	Friction Washer	1	
4	7KT5-005	Screw	2	
5	7KT5-002	Screw	3	
6	7KT5-008	Crank	1	
7	7KT5-056	Pin	1	
8	7KT1-010	Screw	1	
9	7KT5-009	Screw	1	
10	7KT5-010	Sleeve	1	
11	7KT5-011	Slide Block	1	
12	7KT5-012	Washer	1	
13	22WF1-020	Wing Nut	1	
14	7KT5-013	Feed Bar	1	
15	7KT5-014	Collar	2	
16	7KT5-015	Pin	1	
17	7KT5-016	Screw	1	
18	22WF1-020	Setscrew	2	
19	7KT5-043	Rod Connector	1	
20	7KT5-044	Screw	1	
21	7KT5-045	Screw	1	
22	7KT5-046	Screw	1	
23	7KT5-047	Washer	1	
24	7KT5-048	Link	1	
25	7KT5-049	Screw	1	
26	7KT5-050	Nut	1	
27	7KT5-051	Alternating Presser foot	1	
28	7KT5-041	Saddle	1	
29	7KT5-042	Pin	2	
30	7KT5-058	Screw	2	
31	7KT2-019	Screw	1	
32	7KT2-020	Wahser	1	
33	7KT2-021	Eyelet	1	
34	7KT2-022	Screw	1	
35	7KT2-023	Spring Regulator	1	
36	7KT2-024	Setscrew	1	
37	7KT2-025	Sleeve	1	
38	6K4-015	Spring	1	
39	7KT2-026	Check Spring	1	
40	7KT2-027	Washer	1	

41	7KT2-028	Tension Screw	1	
42	7KT2-029	Tension Disc	1	
43	7KT2-030	Tension Plate	1	
44	7KT2-032	Tension Spring	1	
45	7KT2-018	Nut	1	
46	16WF2-012	Spacer	1	
47	16WF2-015	Screw	1	
48	7KT5-028	Crank	1	
49	7KT1-003	Screw	2	
50	7KT5-029	Screw		
51	7KT5-030	Pin	1	
52	7KT5-031	Connecting Rod	1	
53	7KT5-032	Pin	1	
54	7KT5-033	Crank	1	
55	7KT4-029	Screw	1	
56	7KT1-003	Screw	1	
57	7KT5-007	Bushing	1	
58	7KT5-006	Screw	4	
59	7KT5-003	Bracket	1	
60	7KT5-053	Taper Pin	2	

6. UPPER FEEDING AND THREAD TENSION COMPONENTS

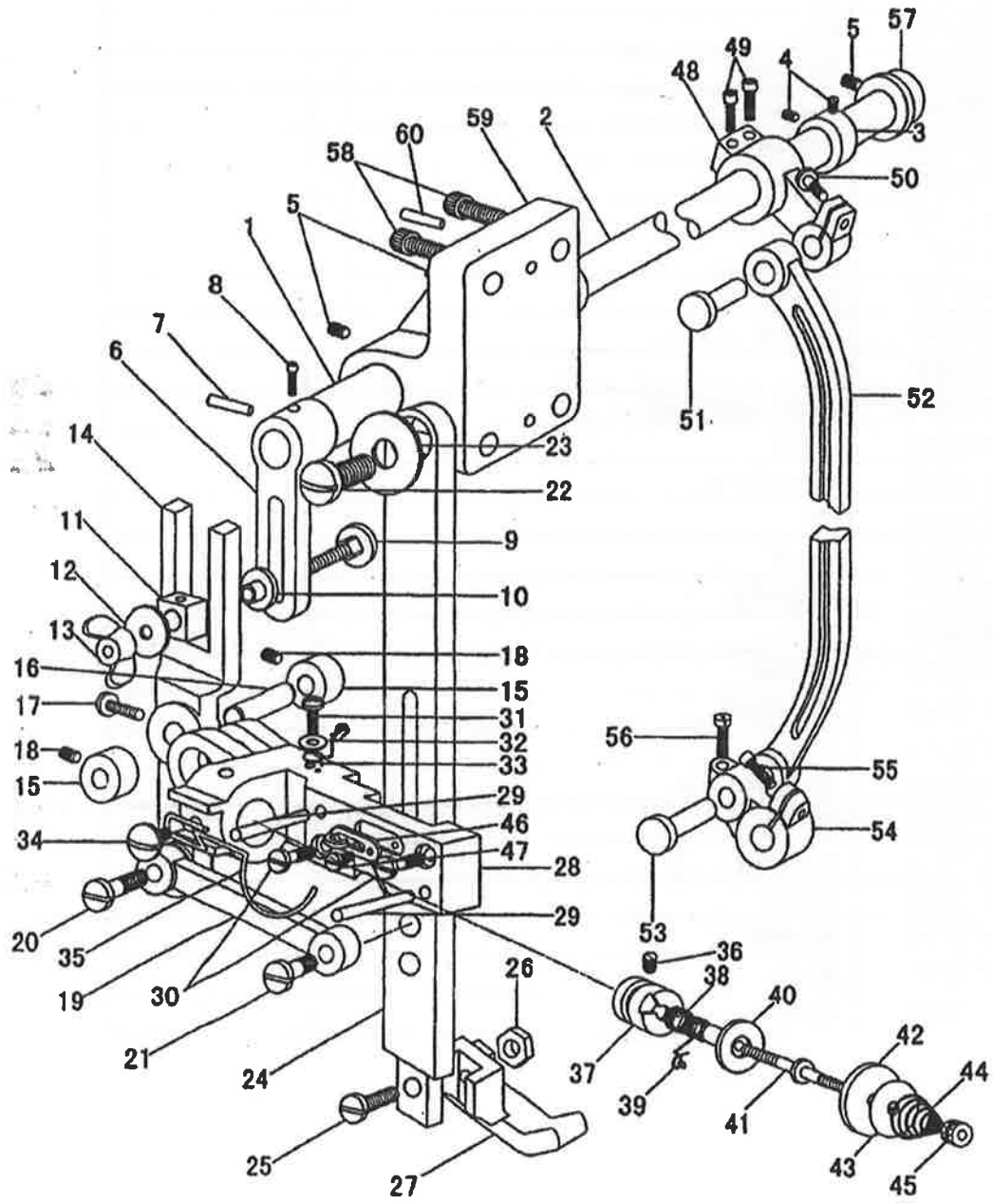

7. LIFT COMPONENTS

No.	Parts No.	Name	Qty	Remark
1	7KT5-020	Screw	2	
2	7KT5-021	Nut	2	
3	7KT5-022	Strap	1	
4	7KT5-0233	Arm	1	
5	7KT5-055	Pin	1	
6	7KT5-024	Setscrew	2	
7	7KT5-025	Shuttle	1	
8	7KT5-026	Bracket	1	
9	7KT5-027	Screw	2	
10	7KT5-054	Pin	2	
11	7KT5-017	Screw	1	
12	7KT5-018	Spacer	1	
13	7KT5-019	Washer	1	
14	7KT1-007	Nut	1	
15	7KT5-034A	Crank Assembly	1	
16	7KT5-034	Crank	1	
17	7KT5-035	Fulcrum Pin	1	
18	7KT5-055	Pin	1	
19	7KT5-036	Crank	1	
20	7KT5-037	Hinge Pin	1	
21	7KT1-007	Nut	1	
22	7KT5-038	Washer	1	
23	7KT5-039	Slide Block	1	
24	7KT5-040	Screw	1	
25	7KT3-030	Hinge Bracket	1	
26	7KT3-031	Screw	1	
27	7KT3-032	Setscrew	1	
28	7KT3-033	Screw	1	
29	7KT3-034	Bracket	1	
30	7KT3-035	Screw	2	
31	7KT5-052	Rollar	1	

7. LIFT COMPONENTS

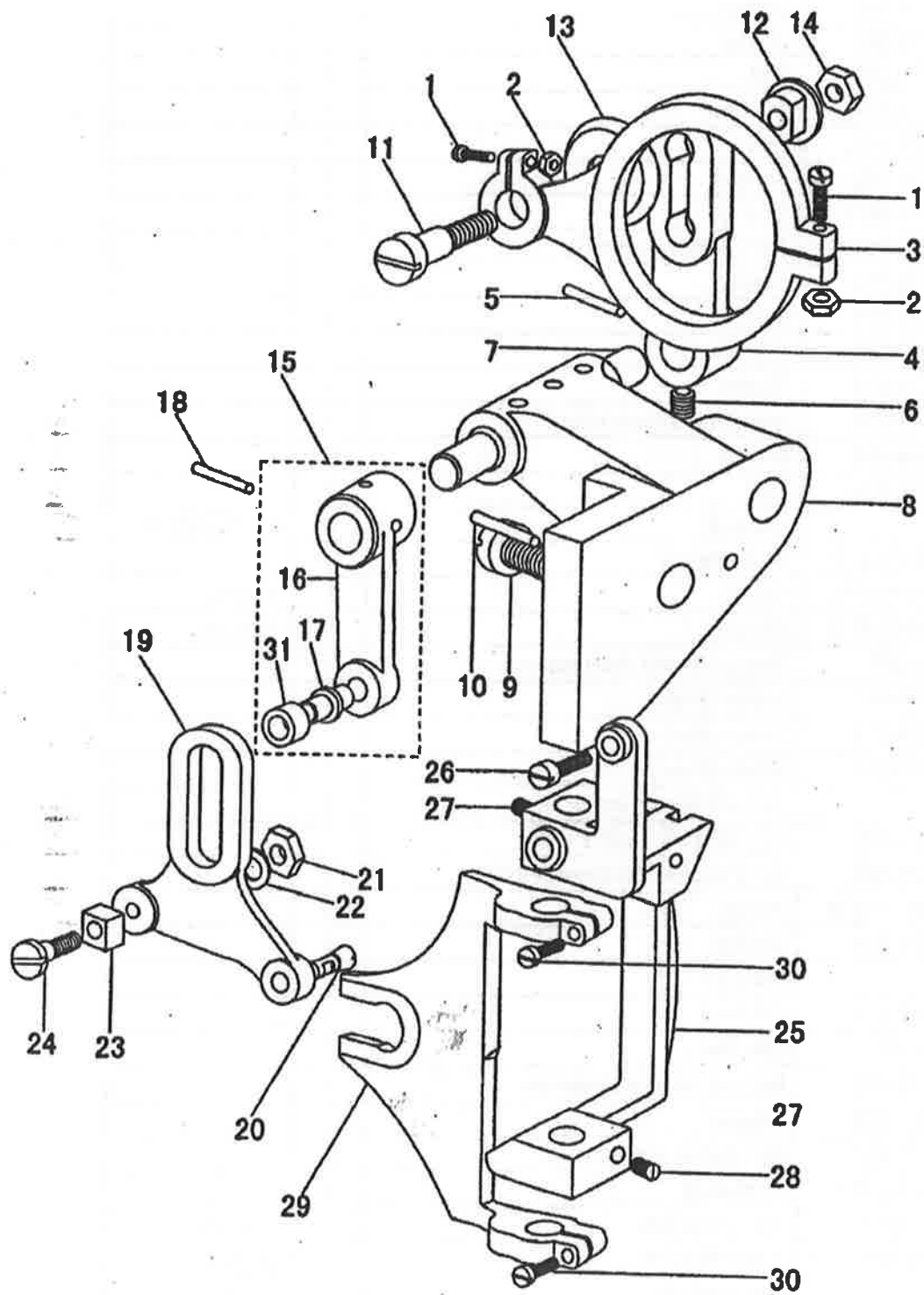

8. ACCESSORIES

No.	Parts No.	Name	Qty	Remark
1	7KT6-004	Oil Box Assembly	1	
2	7KT6-003	Screw	1	
3	7KT6-007	Spring	1	
4	7KT6-008	Felt	2	
5	7KT6-009	Washer	2	
6	7KT6-010	Felt	1	
7	7KT6-002	Screw	1	
8	7KT6-0011	Spring	1	
9	7KT6-0012	Belt Guard Assembly	1	
10	7KT4-004	Screw	1	
11	7KT2-010	Screw	3	
12	7KT6-018	Oil Pan	1	
13	7KT6-019	Screw	4	
14	7KT6-024	Machine Support Foot	2	
15	7KT6-025	Screw	8	
16	7KT6-026	Nut	8	
17		Washer	8	GB7244-87-8
18	18WF1-017	Food Pedal	2	
19	18WF1-016	Chain	1	1000mm
20	18WF1-015	Chain	1	500mm
21	721257	Thread Stand Assembly	1	
22	33TF-012	Screwdriver	1	
23	33TF-013	Screwdriver	1	
24	33TF-014	Screwdriver	1	
25		Cross Screwdriver	1	
26	7KT1-013	Upper Shaft Sleeve	1	
27	7KT6-033	Balance Wheel Shield Plate	1	
28	13WF2-010	Screw	3	
29	7KT1-046	Bobbin	5	
30		Needle	5	
31	33TF-011	Oil Boat	1	
32	1F-012	Oil Can	1	
33	7KT6-030	Bobbin Winder Assembly	1	
34	33TF-018	Washer	2	
35	33TF-017	Self-drilling Screw	2	
36	33TF-010	Parts Bag	1	
37	13F-011	Allen Wrench	1	S=5mm
38	13F-010	Allen Wrench	1	S=4mm
39		Box Wrench	1	11-12
40	7KT6-020	Motor Mounted Plate	1	

41	7KT6-021	Washer	2	
42	7KT6-022	Screw	2	
43	7KT6-023	Nut	2	
44		Timing Belt	1	1400mm

8. ACCESSORIES

